

10/18-0.20 EN



- Communication based on the "HART" protocol
- High operational reliability through regular operational tests
- Electronical adjustment of operating data, in parts automatic (autostroke) and in parts manual
- Easily understandable adjustment mode, adjustment via the built-in operator panel or remotely using the standardized configuration program
- Characteristic linear, equal percentage, or with 20 configurable reference points
- Explosion protection certificates: CENELEC - FM - CSA and others, intrinsically safe and flameproof
- 4...20 mA input, 2-wire, Supply voltage 9.8 V or 10.8 V DC
- Complies with the directives for EMC and CE conformity
- Wide operating temperature range, - 40 bis + 85 °C
- Robust aluminum or stainless steel case
- Influence of shock and vibration <1% with a load of up to 10 g and frequencies between 20 and 80 HZ
- Non-contact (inductive) position sensor
- Stable control loop through self-adaptation and continuous modulation of the output
- Easy to install, all connections on ones side, separate terminal box for wiring
- Attachment to linear or rotary actutators in accordance with the standard
- Low operating cost, air consumption only 0.03 kg/h,

Construction and mode of operation

The concept

The TZID positioner is an intelligent and electronically configurable device with communication capabilities. High-tech electronics are coupled with a robust and well-proven mechanical construction on the pneumatic side to obtain an optimal design of positioner.

The functional heart of the TZID positioner is its CPU (see illustration below). The mechanical and pneumatic assembly groups only have secondary functions. The input signal (set point) and the position (actual value) are fed into the processor via A/D converter. An output signal is computed on the basis of the control deviation and a PD control algorithm. The signal is output to an I/P module via a D/A converter and is used for analog modulation of the I/P module. The I/P module provides for pneumatic, analog adjustment of a 3/3 way valve. The cross-sectional area of the valve air ducts for filling the actuator with air or evacuating air from the actuator is changed in proportion with the adjustment. Continuous signal modulation yields optimal results in terms of precise and rapid control until reaching the set point and in terms of the adaptation to actuators of different sizes and different supply pressures.

The I/P conversion is done with the same I/P module as used for the TEIP 11 signal converter. This well-proven module is already used in the field more than 500.000 times and has an unequalled immunity to shock and vibration.

The TZID positioner has a two-wire 4...20 mA input. The energy needed to power the electronic component parts is derived from the input signal. Compressed air (1.4...6 bar) is the only external energy required. The TZID has a low consumption of less than 4 mA due to the two-wire circuitry, and of only 0.03 kg compressed air per hour.

A rotating feedback shaft for determining the position is the only moving part of the TZID. An inductive, non-contact sensor converts the position into an electrical signal. As a result, the wear-rate is very low.

The TZID positioner provides for maximum operational reliability. Adherence to the EMC regulation ensures immunity to EMF and RFI. The robust IP 65 (NEMA 4X) metal case protects the TZID against harsh environments. Special functions for monitoring that the CPU works properly and that the control point is controlled correctly deliver an alarm message if an error occurs.

The TZID positioner is designed for the operating temperature range of -40 to +85 °C (-40 to +185 °F).

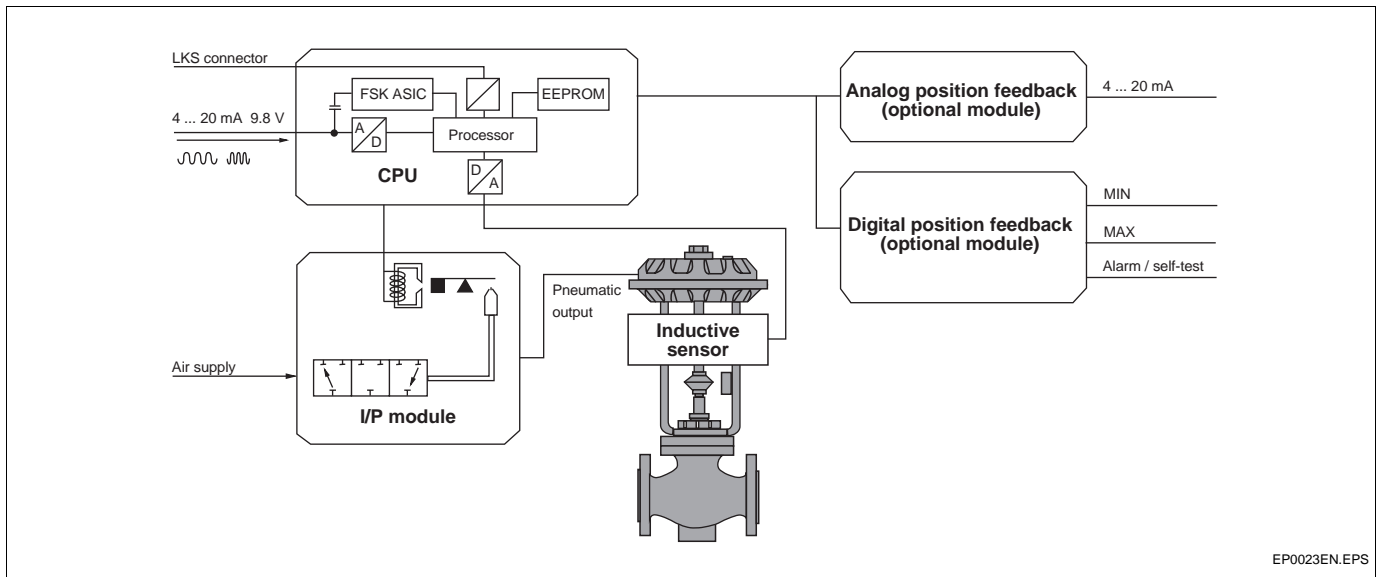

Fig. 1 TZID schematic diagram

Attachment

The TZID can be attached to pneumatic actuators for linear (stroke) or rotary movement (angle of rotation), to actuators with spring return (single acting) or with double air action (double acting).

The off-the-shelf devices are designed for attachment conforming to the standard (lateral attachment to DIN/IEC 534 or attachment to rotary actuators to VDI/VDE 3845). Customized actuator-specific versions for special attachment are available upon request.

When mounting the positioner to an actuator, a rough balancing of the mechanical link for converting the stroke suffices. The wide usable range of the angle of rotation dispenses with the need for a time-consuming mechanical adjustment. The fine adjustment is done automatically through the autostroke.

The air connections and the cable glands are located on the right hand side, making installation easy. NPT connections are provided for the air pipes, and screw terminals are available for connecting the electrical wires.

Construction and mode of operation

Matching to the operating conditions

Various parameters can be set, helping the user to achieve optimal precise control until reaching the setpoint and a high operational reliability. The parameters can be changed while the positioner is on line and working, and are then immediately taken over.

Operating parameters

- Signal range 4 .. 20 mA or split-range
- Valve action
 - Direct: Range 4...20 mA/direction 0...100 %
 - Reverse: Range 20...4 mA/direction 0...100 %
- Characteristic curve (travel = f {positioning signal})
 - linear,
 - equal percentage 1:25 or 1:50 or 25:1 or 50:1,
 - or user-configurable with 20 reference points
- Tolerance band (sensitivity limit)

The factory setting of 0.3 % is a typical value, which only has to be increased in case of very short strokes or high hysteresis values of the valve. Normally, the controller automatically optimizes itself during the autostroke function.
- Travel limiting

The positioning travel, i.e. the stroke or angle of rotation, can be reduced as required within the full range of 0...100%, provided that a minimum value of 20% is observed.
- Shut-off value

This function causes immediate closing of the actuator. The threshold can be configured.

- Adjusted speed for full travel 100 %

This function is used to increase the natural speed for controlling the full travel until reaching the set point. The speed can be set independently for each direction.
- Alarm limits for minimum and maximum positions

This parameter is used to define the switching points for the minimum and the maximum position.

Parameters for diagnosing the operating condition

Prior to preventive maintenance you can make a diagnosis using the following data:

- Counts for the individual control actions and the total displacement of the valve (valve stem). The values indicate the use of the valve. Limits can be defined for both counters. If the limits are exceeded, an alarm is generated

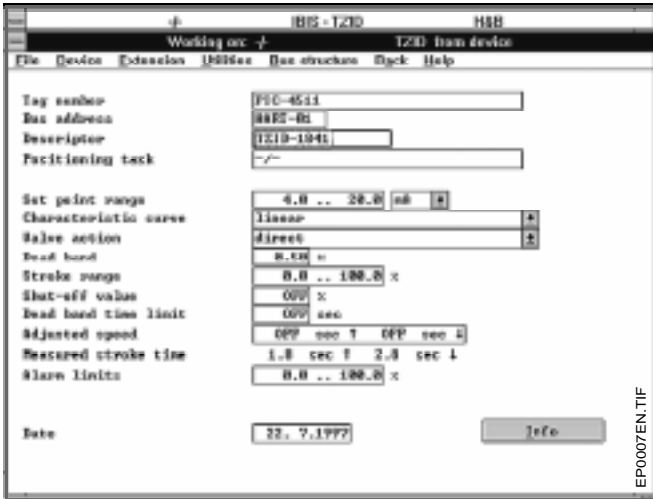

Fig. 2 IBIS window "Device data"

- Time-out monitoring

This function is used to monitor the time needed to reach the set point. It triggers an alarm if the unit is not able to adjust the deviation such that it fits into the tolerance band within the set time.



Fig. 3 IBIS window "Displacement meter"

- Record of the current control operation in tabular form. The defined signal and the controlled position are continuously listed with a high-resolution, adjustable cycle time of 40...160 msec.
- Record of the transfer function in tabular form. The controlled position after a set point jump (position signal) is recorded with an adjustable high-resolution cycle time of 40...160 msec.

The values saved in tabular form can be exported as an EXCEL file and can then be converted into a graphic display.



Fig. 4 IBIS window "Setpoint jump"

Construction and mode of operation

Monitoring functions

The TZID positioner is permanently monitored while it is working. The following list gives some examples for errors that can be detected and indicated:

- Watchdog alarm
- Leakage in the actuator or air pipe
- Signal < 4 or > 20 mA
- Position out of adjusted range (rotation angle) for position feedback
- User actions (manual) affecting CPU operation (controller is not active)
- Positioning time-out (adjustable time parameter)
- Limit of stroke counter or displacement meter exceeded (limits can be adjusted during diagnosis)

If any of these troubles occurs, an alarm is generated and reported, either by indication of an error code on the built-in display or via the option modules (if plugged in).

Extended monitoring is possible via the communication port. The registered troubles are indicated as plain text in a special window (in online mode). Additionally, the most important process variables like the output signal in mA, the position in % and the deviation are indicated.

The operator can decide whether or not the above-listed troubles shall generate an alarm. This can be configured via the communication port and, e.g., the special "Options" window of the IBIS configuration program (see. Fig. 5).

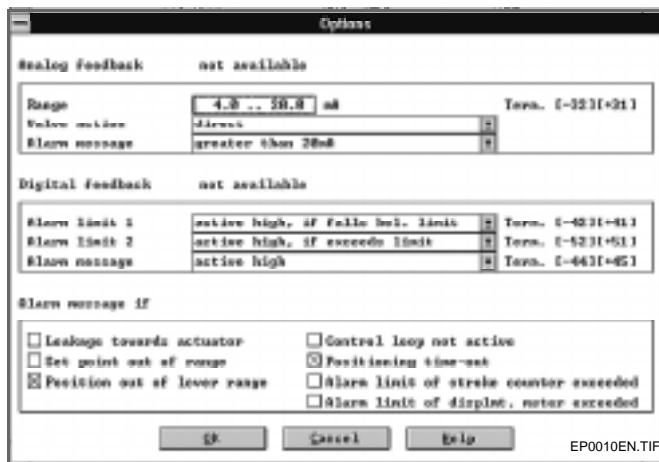

Fig. 5 IBIS window "Options"

Functional check

When the option module for analog or for digital position feedback is connected, it can be checked for proper function and wiring. For this purpose, simulation values can be transmitted to the positioner, e.g. by using the "Simulation" window of the IBIS configuration program (see Fig. 6). While the simulation is active, the TZID positioner is not working in control mode. After around 2 minutes the simulation is stopped automatically. It can also be terminated at any time by actuation of the "Cancel" button.



Fig. 6 IBIS window "Simulation"

Adjustment

The following adjustment parameters are available:

- Full travel of 100 % (stroke or angle of rotation)
- Effective direction of the actuator (direction with compressed air or spring action)
- Valve action (direction of action for opening/closing the valve)
- Controller parameters

Most of these parameters can be adjusted automatically by starting the autostroke function. Only the valve action needs to be adjusted manually.

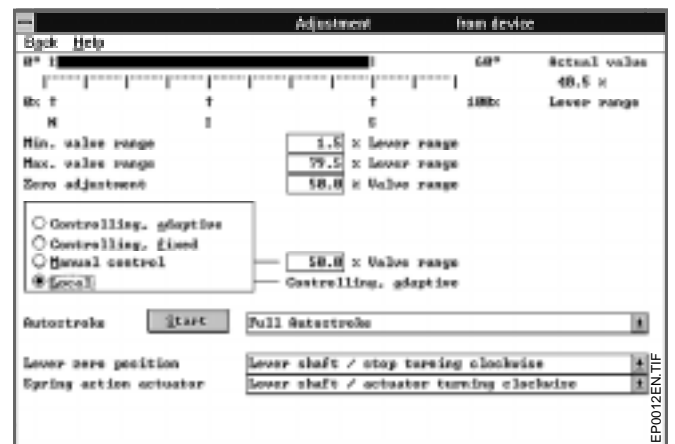

Fig. 7 IBIS window "Adjustment"

Operation and communication

General

The TZID positioner has a built-in operator panel with special adjustment capabilities tailored to commissioning. The full range of TZID functions can only be accessed via the communication port.

On the built-in operator panel you can make any adjustment that is necessary to commission the positioner after attachment to the actuator. The panel is intuitively operable. Short instructions printed on the panel contain the required information.

The full range of functions described above is available via the communication port. Communication is based on the HART protocol. Signals can be tapped either locally at the connector or frequency-modulated at any chosen point of the 4...20 mA signal transmission. Communication is done on line while the system is running, without impairing operation. New parameter settings become active immediately after being downloaded into the device, but have to be stored in the non-volatile memory with a special command.

A special connector (LKS adapter or FSK modem), a standard off-the-shelf PC (which has to meet special hardware requirements), and a special software (e.g. IBIS or Smart Vision®) are needed.

LKS adapter as communication link

The LKS adapter is a connection solution which is both easy to install and cost-saving. On the TZID side a special connector (local communication interface) is used. On the PC side, a double sub-D connector with a 9-pole and a 25-pole connector is used. The connector also accommodates an RS 232 interface converter for connection to the PC.

The TZID can be configured without requiring that a positioning signal is present. The CPU is powered by the PC.

FSK modem as communication link

The FSK modem allows digital frequency-modulated communication (Frequency Shift Keying). The digital signal "0" corresponds to 2.2 kHz, the digital signal "1" to 1.2 kHz. Tapping is possible at any chosen point of 4...20 mA transmission, i.e. directly on site at the TZID or in any remote place, e.g. at a PLS in the control room. Frequency-modulated communication requires a circuit with a resistance of at least 250 ohms

The FSK modem is available with or without electrical isolation. In conjunction with a special isolating amplifier - e.g. Contrans I or Contrans_remote - the model with electrical isolation is suitable for connection to a bus. Communication is also possible with a TZID with explosion protection, provided that the modem itself is placed outside the hazardous area. If these capabilities are not required, you can also use the cost-saving modem without electrical isolation (FSK Modem II). For details and technical data refer to data sheets 10/15-6.97 EN (FSK Modem) and 10/18-0.31 EN (FSK Modem II).

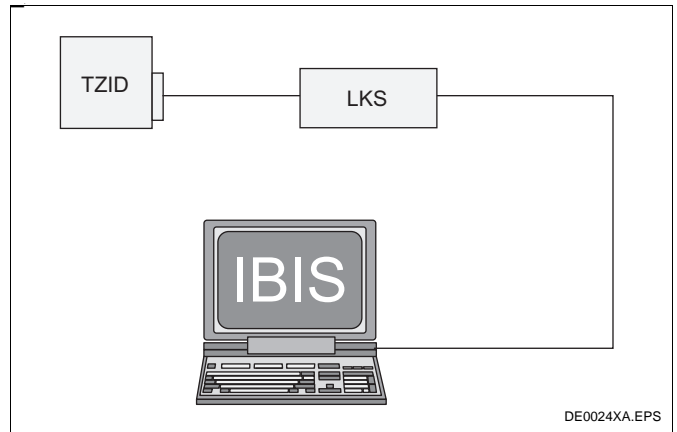

Fig. 8 Communication via LKS adapter

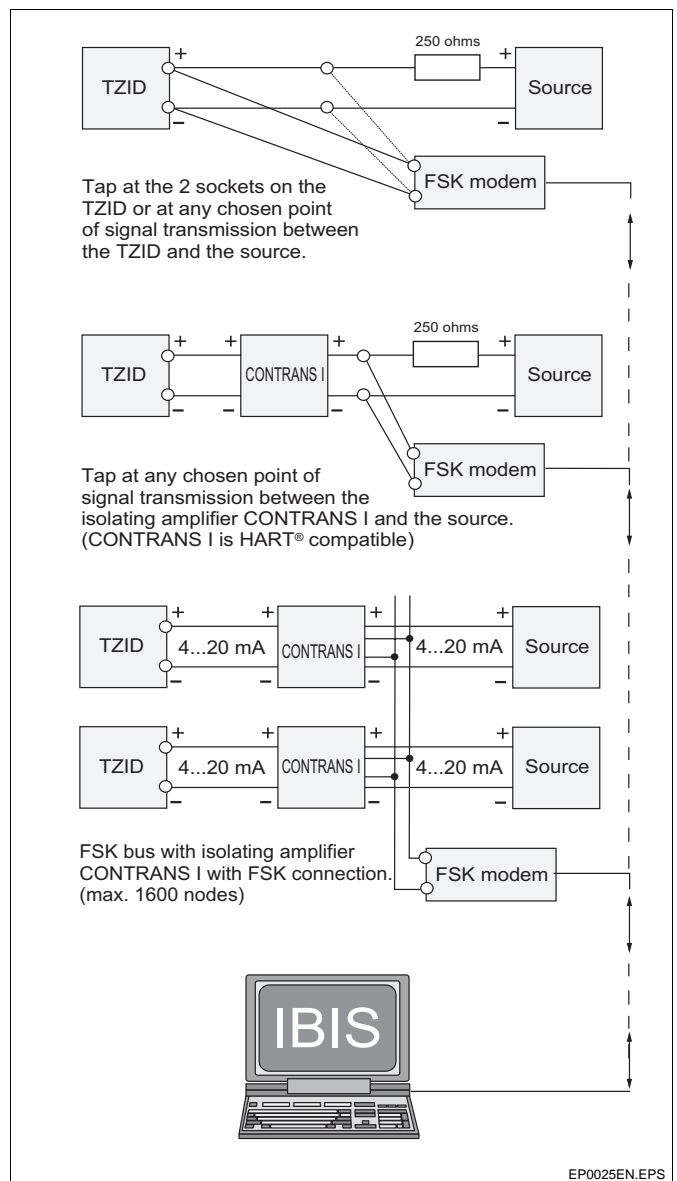

Fig. 9 Communication via Hart® protocol and FSK Modem

Programs

IBIS program

The IBIS (Intelligent Broadcasting and Information System) program is a windows-type graphical user interface with user-friendly and intuitively operable standardized windows. IBIS offers comfortable functions for configuring, monitoring and testing intelligent field and control room instruments.

You can install and call up IBIS in different languages, select the communication interface as required, and protect access with a password. IBIS is controlled via mouse or keyboard. Context-sensitive on-line help can be called up for all menu items by pressing the < F1 > key.

Further details are available upon request.

Hardware requirements

Computer	PC/Notebook for DOS or WINDOWS, (IBM compatible) 386 or higher
Operating system	Microsoft DOS 3.2 or higher Microsoft WINDOWS 3.1 or higher
RAM	at least 640 Kbytes (580 Kbytes free) for DOS at least 4 Mbytes for WINDOWS
Graphics card	CGA, EGA, VGA or Hercules for DOS VGA for WINDOWS
Hard disk	at least. 2.5 Mbytes free memory
Disk drive	3 1/2", 1.44 Mbytes
Monitor	Monochrome, color or LCD
Interface	RS 232 C for communication CENTRONICS for printer (optional)

Smart Vision® program

The Smart Vision® program has the same "look" as "WINDOWS", i.e. it has similar intuitively operable windows, and commands can be entered in the same way. Everybody who is familiar with "WINDOWS" can easily work with Smart Vision® as well. Therefore, you have to refer to the user's guides only every now and then.

The Smart Vision® communication program can be used with our HART compatible devices. Due to its open structure Smart Vision® allows communication with other devices as well. Defined commands can be realized easily by using available tools and without requiring major efforts.

Smart Vision® enables:

- Configuration or setting of parameters of the devices
- Display of measured values digitally, as bargraph display or as trend display (curve)
- Diagnosis and retrieval of status messages
- Storage of data, e.g. of configuration data of the device
- Data output, e.g. to the printer
- Planning and administration of TAGs

Further details are available upon request.

Hardware requirements

Computer	PC/Notebook for WINDOWS (IBM compatible) 486 or higher
Operating system	Microsoft WINDOWS 3.1 or higher Microsoft WINDOWS 95 or WINDOWS NT
Hard disk	at least 2 Mbytes of free memory
RAM	at least 500 Kbytes of free memory
Disk drive	3 1/2" (1.44 MB) or CD ROM
Interface	RS 232 C for communication

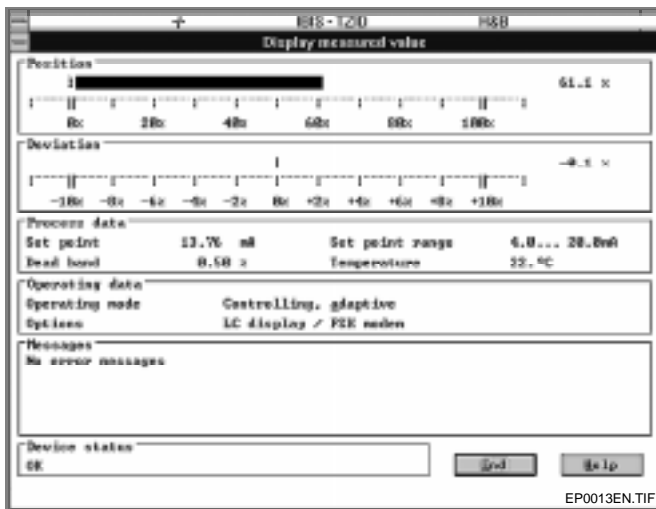

Fig. 10 Typical IBIS window

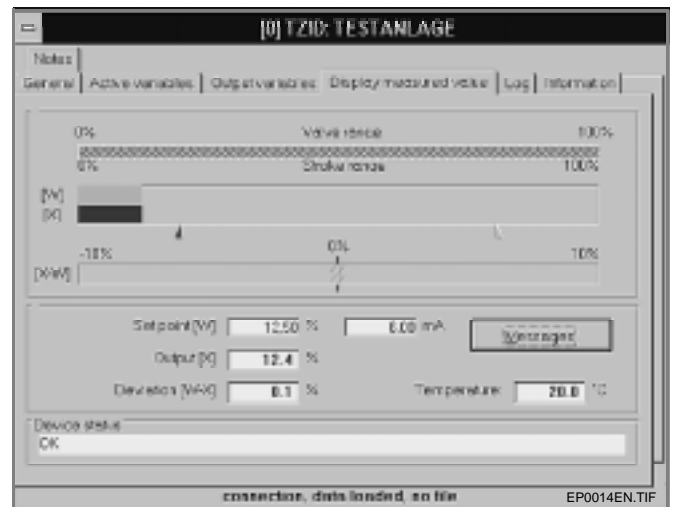

Fig. 11 Typical Smart Vision® window

Technical data

Input

Signal range

- Nominal range 4...20 mA
- Split ranges configurable between 20 and 100 %

Two-wire circuitry

- Supply voltage 9.8 VDC without explosion protection
- 9.8 VDC with Ex d approval
- 10.8 VDC for intrinsically safe device

Resistance

- 490 ohms at 20 mA and 9.8 VDC
- 540 ohms at 20 mA and 10.8 VDC

Output

Signal range

- 0...6 bar (0...90 psi)

Air capacity

- At supply pressure of 1.4 bar (20 psi)
- 5.5 kg/h = 4.5 Nm³/h = 2.5 scfm

- At supply pressure of 6 bar (90 psi)
- 13 kg/h = 11 Nm³/h = 6.5 scfm

(Booster for increase of capacity available on request)

Action

- Single or double, air is evacuated from actuator or actuator is blocked in case of (electrical) power failure

Shut off value

- Setable to 0...20 % of positioning signal
- (if the value falls below the set value, the positioner immediately sets the actuator to the closed position)

Stroke movement

Angle of rotation

- 60 ° nominal range for attachment to linear actuators in accordance with DIN/IEC 534
- 120 ° nominal range for attachment to rotary actuators in accordance with VDI/VDE 3845

Used range is 20...100 % of nominal range

Adjusted speed

- Range 0...200 sec,
- individually configurable for each direction

Time-out monitoring

- Range 0...200 sec (monitoring parameter for control until the deviation is within the tolerance band)

Stroke limiting

- Min. and max. limits, setable between 0 and 100 % of the stroke

Air supply

Instrument air

- free of oil, water and dust to DIN/ISO 8573-1
- pollution and oil contents according to Class 3
- dew point 10 K below operating temperature

Supply pressure

- 1.4...6 bar (20...90 psi)

Caution:

Do not exceed the max. working pressure of the actuator!

Air consumption

- < 0.03 kg/h (independent of supply pressure)

Transmission data and influences

Effective direction (output signal or pressure in actuator)

- Increasing: Increasing signal 4...20 mA
- Increasing pressure y_1 in actuator

- Decreasing: Increasing signal 4...20 mA
- Decreasing pressure y_1 in actuator

Valve action

- Direct: Range 4...20 mA = position 0..100 %
- Reverse: Range 20...4 mA = position 0..100 %

Characteristic curve (travel = f{signal})

- linear,
- equal percentage 1:25 or 1:50 or 25:1 or 50:1,
- or user-configurable with 20 reference points

Characteristic deviation

- ≤ 0.5 %

Dead band (sensitivity)

- Adjustable from 0.3...10 %

Resolution (A/D conversion)

- > 8000 steps

Sample rate

- 20 msec

Influence of ambient temperature

- ≤ 0.5 % for every 10 K

Influence of vibration

- ≤ 1 % up to 10 g and 20...80 Hz

Seismic requirements

- Meets requirements of DIN/IEC 68-3-3 class III for strong and strongest earthquakes

Influence of mounting orientation

- No effect

EMC

- Meets EMC directive 89/336/EEC as of May 1989

CE mark

- Meets the EC directive for the CE conformity certification

Communication port

- Connector for LKS adapter (standard)
- FSK module for frequency-modulated tapping (optional)

Environmental capabilities

Climate class

- GPF to DIN 40040

Ambient temperature

- 40 to +85 °C (-40 to +185 °F)
- for operation, storage and transport

Technical data

Explosion protection

CENELEC

Ex ia IIC T4/T5/T6, PTB No. Ex-94.C.2133 X
 Ex d IIC T4/T5/T6, BVS No. 96.D.2008 X

BRITISH Standards 6941:1988

Ex N IIC T6, Certificate SCS No: Ex95Y4126X

FM

Intrinsically Safe CL I-II-III, Div 1, Grp A-B-C-D-E-F-G
 Non-incendive CL I-II-III, Div 2, Grp A-B-C-D-E-F-G
 Explosion-proof CL I-II-III, Div 1, Grp B-C-D-E-F-G

CSA

Intrinsically Safe CL I, Div 1, Grp A-B-C-D
 CL II, Div 1, Grp E-F-G
 Non-incendive CL I, Div 2, Grp A-B-C-D
 CL II, Div 2, Grp E-F-G
 Explosion-proof CL I, Div 1, Grp C-D
 CL II, Div 1, Grp E-F-G

Case

Material

Aluminum, protection IP 65 (NEMA 4X)
 Surface
 Case black, RAL 9005, matt
 Cover light gray, RAL 9002
 with thick film epoxy resin electro-dipcoat
 Stainless steel 1.4581, protection IP 65 (NEMA 4X)

Electrical connections

Screw terminals, internal, for 2.5 mm²

Cable entry

Threads Pg. 13.5 or 1/2-14 NPT or M 20 x 1.5
 (depending on model and order)

For TZID models "standard", "intrinsically safe" or "Ex N IIC" with Pg. 13.5 thread the PG 13.5 cable glands are delivered with the device.

For TZID model Ex d with thread M 20 x 1.5 the EEx d IIC cable glands are delivered only upon special request (certificate of conformity INEX 88B.103.748).

Pneumatic connections

G 1/4 or 1/4-18 NPT threads

Weight

2.9 kg (TZID, main catalog no.18341, with aluminum case)
 5.6 kg (TZID, main catalog no. 18341, with stainless steel case)
 5.8 kg (TZID Ex d, main catalog no. 18342, with aluminum case)

Mounting position

As required

Options

Option module for analog feedback

Signal range 4...20 mA (split ranges configurable)
 Two-wire circuitry, power supply 10...30 V DC
 Standard or intrinsically safe version
 Valve action direct or reverse (as configured)
 Characteristic deviation ≤ 1 %
 (Whether the module is to be used for alarm reporting and whether the output is to be modulated to < 4 or > 20 mA can be configured).

Option module for digital feedback

3 switches for current circuits in accordance with DIN 19234
 Control voltage 8...25 V DC
 Control current < 1.2 mA = switching state logical "0"
 Control current > 2.1 mA = switching state logical "1"

Direction of action: normally logical "0" or logical "1" (as configured)

Standard or intrinsically safe version

Switch assignment: 1 switch for alarms
 2 switches for position (adjustable between 0 and 100 %)

Mechanical kit for digital position feedback

2 proximity switches for current circuits in acc. with DIN 19234
 Control voltage 5...25 V DC
 Control current < 1 mA = switching state logical "0"
 Control current > 3 mA = switching state logical "1"
 Standard or intrinsically safe version¹⁾
 For min. or max. position
 Limits adjustable between 0 and 100 %
 (Function independent of the software and electronics of the positioner)

Direction of action (logical state):

Proximity switch	Position			
	< min	> min	< max	> max
SJ2-SN (NC)	0	1	1	0
SJ2-S1N (NO) ²⁾	1	0	0	1

1) CENELEC EEx ia IIC T1...T6, PTB No. Ex-83/2022 X

2) Lower limit of operating temperature range: - 25 °C

Accessories

Attachment material

- Attachment kit for linear actuators, stroke 10...85 mm (lateral attachment meets DIN/IEC 534 or Namur)
- Lever 170 mm for linear actuators, stroke 10...150 mm
- Attachment bracket for rotary actuators 90 °
- Attachment to VDI/VDE 3845, dimensions A/B = 80/20 mm
- = 80/30 mm
- = 130/30 mm
- = 130/50 mm

Attachment kit for actuator-specific attachment available on request

Pressure gauges for supply pressure and output pressure

- Plastic or stainless steel case, Ø 40 mm
- Supply pressure range 0...10 bar/0...140 psi
- Output pressure range 0...10 bar/0...140 psi
- or 0...4 bar/0...60 psi

With connection block and attachment material for the TZID

Connection block made of aluminum with black varnish or of stainless steel

Filter regulator with attachment material

- All metal version, brass, varnished black
- Bronze filter element, 40 µm, with condensate drain
- Max. pre-pressure 16 bar,
- output pressure adjustable to 1.4...6 bar

PC adapter for communication

- LKS adapter for connector on TZID
- FSK modem for frequency-modulated tapping

Configuration program

- IBIS for TZID/DOS 3 1/2" disk
- IBIS for TZID/WINDOWS3 1/2" disk
- Smart Vision® 3 1/2" disk
- Smart Vision® as CD ROM

Isolating amplifier for signal range 0/4...20 mA

- Contrans I or Contrans_remote
- (see separate data sheets for details)

Fig. 11 TZID positioner with attached pressure gauge block and filter regulator

(if not otherwise agreed, the pressure gauge block and the filter regulator are delivered as separate units for mounting by the customer)

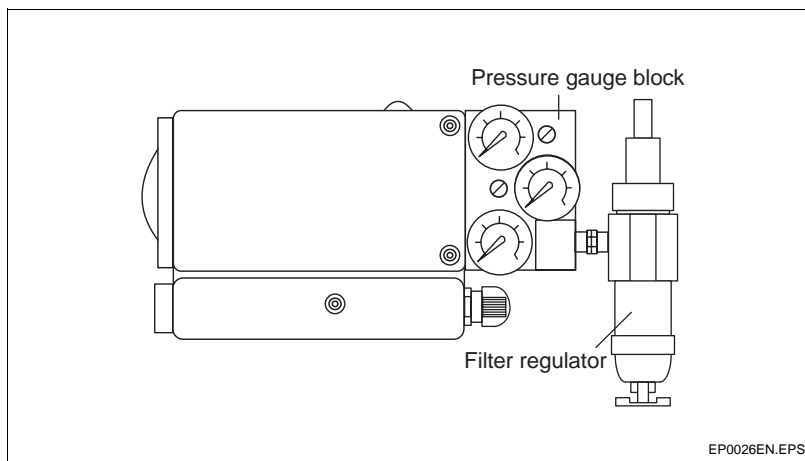
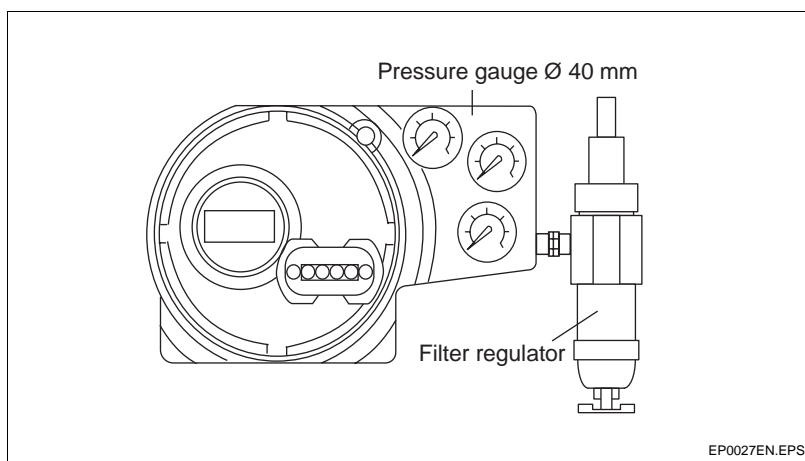

Fig. 12 TZID Ex d positioner with screwed-in pressure gauges and attached filter regulator

(if not otherwise agreed, the pressure gauges and the filter regulator are delivered as separate units for mounting by the customer)



Ordering information (models "standard", "intrinsically safe" or "Ex N")										
		Catalog No								
Intelligent positioner TZID electropneumatic, configurable with display and operating panel signal input 4 ... 20 mA, two-wire		V18341-								
Case material aluminium, varnished, protection IP 65 stainless steel 1.4581, protection IP 65		A								
Communication port and attachment with plug connector for LKS adapter attachment to linear actuators to DIN/IEC 534 attachment to rotary actuators 90° to VDI/VDE 3845 for aluminium case for stainless steel case with plug connector for LKS adapter and FSK modem attachment to linear actuators to DIN/IEC 534 attachment to rotary actuators 90° to VDI/VDE 3845 for aluminium case for stainless steel case with plug connector for LKS adapter for actuator-specific attachment (please specify) with plug connector for LKS adapter and FSK modem for actuator-specific attachment (please specify) *) Coding acc. to special device application (see separate data sheet) Note: For attachment according to standard additional mounting material as listed in chapter "accessories" is required.		1	2	3	5	6	7	*)	*)	
Explosion protection without CENELEC EEx ia IIC CENELEC EEx ia IIC, for inflammable gas for aluminium case for stainless steel case FM / CSA intrinsically safe BRITISH Standards Ex N IIC (further approvals upon request)		0	1	2	5	3	4			
Controller output / safe position single acting air is evacuated from actuator in case of electrical power failure actuator is blocked in case of electrical power failure double acting air is evacuated from actuator in case of electrical power failure actuator is blocked in case of electrical power failure		1	2	4	5					
Connections Cable: thread Pg. 13.5 1/2-14 NPT Pg. 13.5 Air pipe: thread G 1/4 1/4-18 NPT 1/4-18 NPT Note: Protection FM/CSA intrinsically safe only with cable connections 1/2-14 NPT thread		1	2	3						

Ordering information (models "standard", "intrinsically safe" or "Ex N")										
		Catalog No								
Intelligent positioner TZID electropneumatic, configurable with display and operating panel signal input 4 ... 20 mA, two-wire		V18341-								
Supplementary modules										
without										
Supplementary module for:										
Analog position feedback, signal range 4 ... 20 mA, two-wire										
without explosion protection										
intrinsically safe CENELEC or FM/CSA or BRITISH Standards Ex N IIC										
Digital feedback for min. / max. position and for alarms										
without explosion protection										
intrinsically safe CENELEC or FM/CSA or BRITISH Standards Ex N IIC										
Mechanical kit for digital feedback of the min. / max. position										
with proximity switches SJ2-SN (NC or logical 1)										
without explosion protection										
intrinsically safe CENELEC or BRITISH Standards Ex N IIC										
with proximity switches SJ2-S1N (NO or logical 0)										
without explosion protection										
intrinsically safe CENELEC or BRITISH Standards Ex N IIC										
Supplementary module for analog position feedback, signal range 4 ... 20 mA										
combined with										
mechanical kit for digital feedback of the min./max. position										
with proximity switches SJ2-SN (NC or logical 1)										
without explosion protection										
intrinsically safe CENELEC or BRITISH Standards Ex N IIC										
with proximity switches SJ2-S1N (NO or logical 0)										
without explosion protection										
intrinsically safe CENELEC or BRITISH Standards Ex N IIC										
Ready for addition of supplementary modules for analog or digital position feedback										
Note:										
No FM/CSA certificate for mechanical kit for digital position feedback.										
Labeling (language)										
German										
English										
French										
(other languages upon request)										
Design (varnish/coding)										
standard										
(other designs upon request)										

Accessories for models "standard" or "intrinsically safe" or "Ex N"				
	Catalog No			
Attachment material and cost				
Attachment kit for linear actuators, stroke 10 ... 85 mm, For lateral attachment to DIN/IEC 534 (for aluminium case) (for stainless steel case)	18391-0319601 18391-7959054			
Lever 170 mm for stroke 10 ... 150 mm (to be ordered additionally for linear actuators with stroke > 85 mm) (for aluminium case) (for stainless steel case)	18391-0319602 18391-7959055			
Attachment bracket for rotary actuator 90° for mounting to VDI/VDE 3845 Bracket, dimensions A/B 80/20 mm (for aluminium case) (for stainless steel case)	18391-0319603 18391-7959056			
80/30 mm (for aluminium case) (for stainless steel case)	18391-0319604 18391-7959057			
130/30 mm (for aluminium case) (for stainless steel case)	18391-0319605 18391-7959058			
130/50 mm (for aluminium case) (for stainless steel case)	18391-0319606 18391-7959059			
Note: Attachment kit for actuator-specific attachment: see additional list				
Attachment cost				
Attachment cost for attachment to DIN/IEC 534 or VDI/VDE 3845 including material for piping and adjustment piping with plastic tube piping with copper tube piping with stainless steel tube	18391-0319628 18391-0319629 18391-0319630			
Note: Attachment cost for actuator-specific attachment: see additional list				
Adapter and operating program for digital communication				
LKS adapter	18389-0319621			
Standard FSK modem (with electrical isolation)	18389-0319622			
FSK modem II (without electrical isolation)	18931-0319237			
Operating program IBIS for TZID/DOS (as 3 1/2" disk)	18395-0319623			
Operating program IBIS for TZID/WINDOWS (as 3 1/2" disk)	18395-0319625			
Note: Operating program "Smart Vision" see additional list				

Accessories for models "standard" or "intrinsically safe" or "Ex N"				
	Catalog No			
Pressure gauge block				
Pressure gauge block with pressure gauge Ø 40 mm, inclusive attachments for TZID with single-acting output, with 2 pressure gauges (1x for air pressure 0 ... 10 bar/0 ... 140 psi and 1x for output pressure)				
Connectors G 1/4				
Output pressure range 0 ... 4 bar/0 ... 60 psi	aluminium version	18391-7959060		
	stainless steel version	18391-7959066		
Output pressure range 0...10 bar/0...140 psi	aluminium version	18391-7959061		
	stainless steel version	18391-7959042		
Connectors 1/4-18 NPT				
Output pressure range 0 ... 4 bar/0 ... 60 psi	aluminium version	18391-7959064		
	stainless steel version	18391-7959067		
Output pressure range 0...10 bar/0...140 psi	aluminium version	18391-7959030		
	stainless steel version	18391-7959045		
for TZID with double-acting output, with 3 pressure gauges (1x for air pressure 0 ... 10 bar/0 ... 140 psi and 2x for output pressure)				
Connectors G 1/4				
Output pressure range 0 ... 4 bar/0 ... 60 psi	aluminium version	18391-7959062		
	stainless steel version	18391-7959068		
Output pressure range 0...10 bar/0...140 psi	aluminium version	18391-7959063		
	stainless steel version	18391-7959043		
Connectors 1/4-18 NPT				
Output pressure range 0 ... 4 bar/0 ... 60 psi	aluminium version	18391-7959065		
	stainless steel version	18391-7959069		
Output pressure range 0...10 bar/0...140 psi	aluminium version	18391-7959031		
	stainless steel version	18391-7959046		
Note:				
The pressure gauge blocks are delivered as separate units for self-assembly				
Version "aluminium" means gauge block made of aluminium, varnished black and gauge housing made of black plastic.				
Version "stainless steel" means gauge block made of stainless steel and gauge housing made of stainless steel.				
Filter regulator				
Brass filter regulator, varnished black inclusive of material for attachment to pressure gauge block				
	connectors G 1/4	18391-7959048		
	1/4-18 NPT	18391-7959049		
Note:				
The filter regulators are delivered as separate units for self-assembly				
Stainless steel filter regulator not available				

Ordering information (model "Ex d, flameproof")										
		Catalog No								
Intelligent positioner TZID Ex d electropneumatic, configurable with display and operating panel signal input 4 ... 20 mA, two-wire		V18342-								
Case material Aluminium, varnished, protection IP 65		A								
Communication port and attachment with plug connector for LKS adapter Attachment to linear actuators to DIN/IEC 534 Attachment to rotary actuators 90° to VDI/VDE 3845 with plug connector for LKS adapter and FSK modem Attachment to linear actuators to DIN/IEC 534 Attachment to rotary actuators 90° to VDI/VDE 3845 Note: For required mounting kits see under "Accessories" For versions for actuator specific mounting see additional list			1							
			2							
			5							
			6							
Explosion protection CENELEC EEx d IIC FM / CSA explosion proof (further approvals upon request)			1							
			3							
Controller output / safe position Single acting air is evacuated from actuator in case of electrical power failure actuator is blocked in case of electrical power failure Double acting air is evacuated from actuator in case of electrical power failure actuator is blocked in case of electrical power failure			1							
			2							
			4							
			5							
Connections Cable: thread M 20x1.5 1/2-14 NPT Air pipe: thread G 1/4 1/4-18 NPT Note: Protection FM/CSA explosion proof only with cable connections 1/2-14 NPT thread			1							
			2							

Ordering information (model "Ex d, flameproof")											
				Catalog No							
Intelligent positioner TZID Ex d electropneumatic, configurable with display and operating panel signal input 4 ... 20 mA, two-wire				V18342-							
Supplementary modules											
without								0	0		
Supplementary module for analog position feedback, signal range 4 ... 20 mA, two-wire								2	0		
digital position feedback for min. / max. position and for alarms								6	0		
Mechanical kit for digital feedback of the min. / max. position with proximity switches SJ2-SN (NC or logical 1)								8	2		
with proximity switches SJ2-S1N (NO or logical 0)								8	4		
Supplementary module for analog position feedback, signal range 4 ... 20 mA, combined with mechanical kit for digital feedback of the min./max. position with proximity switches SJ2-SN (NC or logical 1)								2	2		
with proximity switches SJ2-S1N (NO or logical 0)								2	4		
Ready for addition of supplementary modules for analog or digital position feedback								9	0		
Labeling (language)											
German								1			
English								2			
French								3			
(other languages upon request)											
Design (varnish/coding)											
standard (other designs upon request)								1			

Accessories for models "Ex d, flameproof"				
	Catalog No			
Attachment material and cost				
Attachment kit for linear actuators, stroke 10 ... 85 mm, for lateral attachment to DIN/IEC 534	18391-0319601			
Lever 170 mm for stroke 10 ... 150 mm (to be ordered separately for linear actuators with stroke > 85 mm)	18391-0319602			
Attachment bracket for rotary actuator 90° for mounting to VDI/VDE 3845				
Bracket, dimensions A/B 80/20 mm	18391-0319603			
80/30 mm	18391-0319604			
130/30 mm	18391-0319605			
130/50 mm	18391-0319606			
Note: Attachment kit for actuator-specific attachment see additional list				
Attachment cost				
Attachment cost for attachment to DIN/IEC 534 or VDI/VDE 3845 including material for piping and adjustment				
piping with plastic tube	18391-0319628			
piping with copper tube	18391-0319629			
piping with stainless steel tube	18391-0319630			
Note: Attachment cost for actuator-specific attachment see additional list				
Cable gland Ex d				
Cable gland EEx d IIC, brass, nickel-plated, threaded stem M 20x1.5, cable Ø 9 ... 11 mm	18391-0319343			
Note: The cable gland is delivered as a separate unit for self-assembly				
Adapter and operating program for digital communication				
LKS adapter	18389-0319621			
Standard FSK modem (with electrical isolation)	18389-0319622			
FSK modem II (without electrical isolation)	18931-0319237			
Operating program IBIS for TZID/DOS (as 3 1/2" disk)	18395-0319623			
Operating program IBIS for TZID/WINDOWS (as 3 1/2" disk)	18395-0319625			
Operating program Smart Vision® (as CD-ROM)	List 63-1.20			

Accessories for model "Ex d, flameproof"				
	Catalog No			
Pressure gauge				
Pressure gauge Ø 40 mm, black plastic case for TZID with single-acting output, with 2 pressure gauges (1x for air pressure 0 ... 10 bar/0 ... 140 psi and 1x for output pressure) output pressure range 0 ... 4 bar/0 ... 60 psi output pressure range 0...10 bar/0...140 psi	18391-0319643 18391-0319644			
for TZID with double-acting output, with 3 pressure gauges (1x for air pressure 0 ... 10 bar/0 ... 140 psi and 2x for output pressure) output pressure range 0 ... 4 bar/0 ... 60 psi output pressure range 0...10 bar/0...140 psi	18391-0319645 18391-0319646			
Note: The pressure gauges are delivered as separate units for mounting by the customer				
Filter regulator				
Brass filter regulator, varnished black inclusive of adapter for attachment to TZID Ex d positioner connectors G 1/4 1/4-18 NPT	18391-7959070 18391-7959071			
Note: The filter regulators are delivered as separate units for mounting by the customer				

Stock versions								
					Catalog No			
Intelligent positioner TZID electropneumatic, configurable with display and operating panel signal input 4 ... 20 mA, two-wire attachment to linear actuators to DIN/IEC 534								
Ex-prot.	FSK modem	Output Safe position	Connections	Options				
without	without	single acting air evacuated	Pg. 13.5 G 1/4	analog pos. feedback	18341-A10111011			
without	with	single acting air evacuated	Pg. 13.5 G 1/4	without	18341-A50110011			
EEx ia	with	single acting air evacuated	Pg. 13.5 G 1/4	without	18341-A51110011			
EEx ia	with	single acting air evacuated	1/2-14 NPT 1/4-18 NPT	ready for addition	18341-A51129011			
Intelligent positioner TZID electropneumatic, configurable with display and operating panel signal input 4 ... 20 mA, two-wire attachment to rotary actuators 90° to VDI/VDE 3845								
Ex-prot.	FSK modem	Output Safe position	Connections	Options				
without	without	single acting air evacuated	Pg. 13.5 G 1/4	analog pos. feedback	18341-A20111011			
without	with	double acting air evacuated	Pg. 13.5 G 1/4	without	18341-A60410011			
EEx ia	with	double acting air evacuated	1/2-14 NPT 1/4 18 NPT	ready for addition	18341-A61429011			

Dimensional drawings of TZID models "standard", "intrinsically safe" or "Ex n"

Lateral attachment to DIN / IEC 534

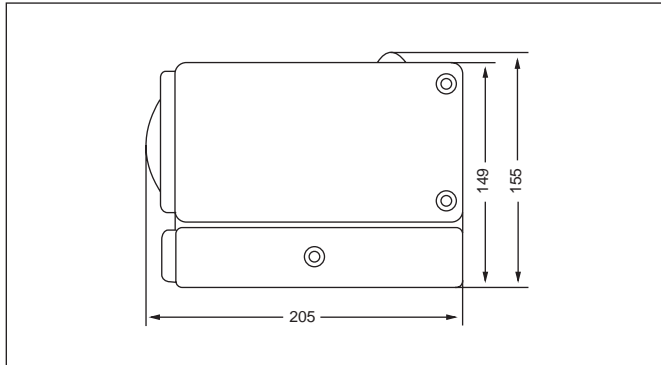

Front view

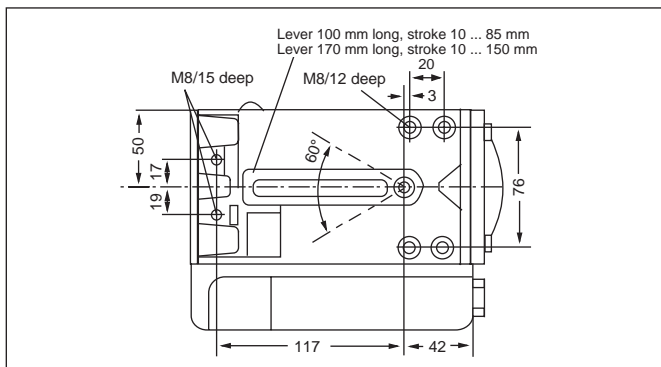

Rear view

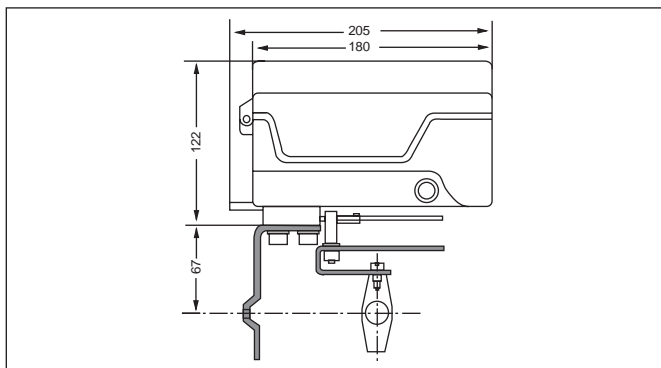

Bottom view

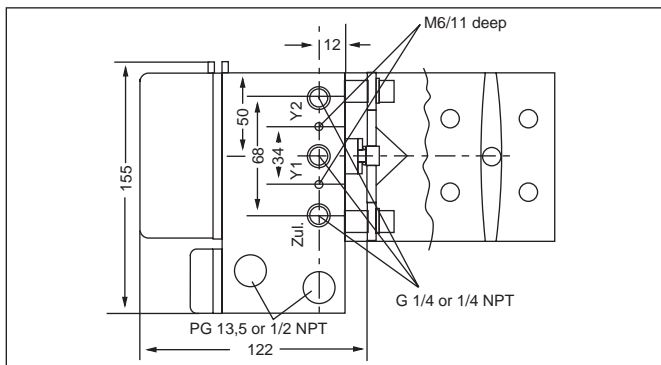

Side view (right)

Attachment to rotary actuator to VDI / VDE 3845

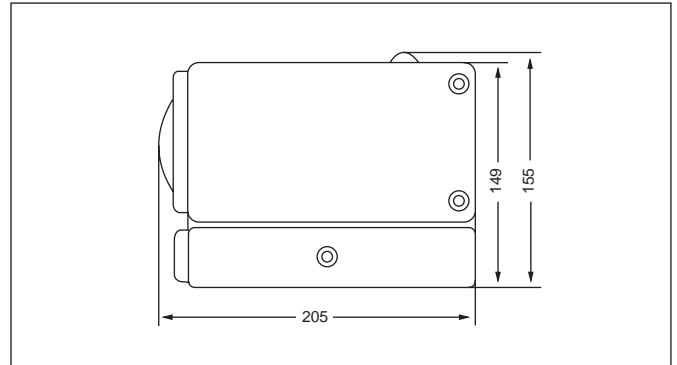

Front view

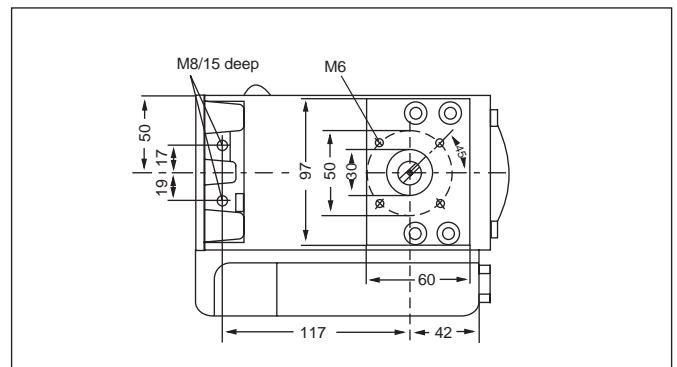

Rear view

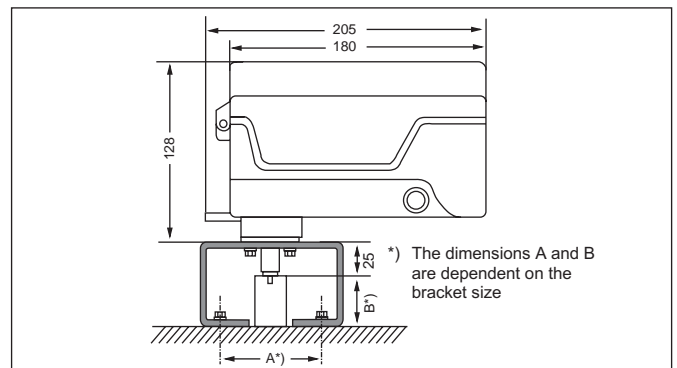

Bottom view

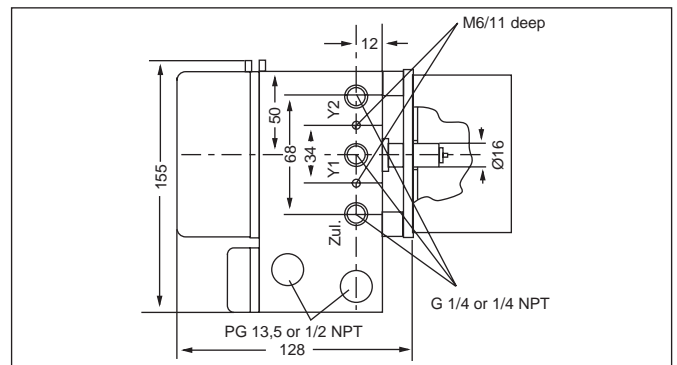

Side view (right)

EP0029EN.EPS

Dimensional drawings of TZID models "Ex d", flameproof

Lateral attachment to DIN / IEC 534

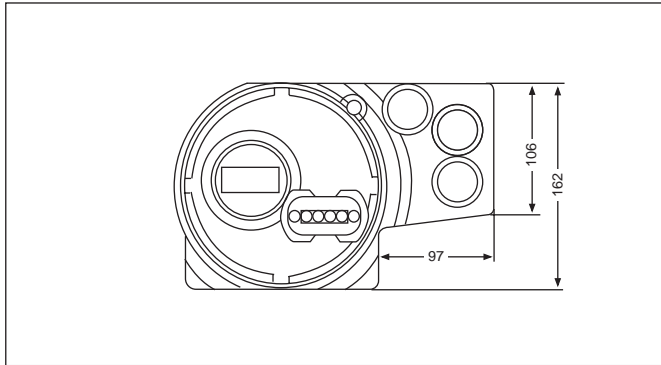

Front view

Attachment to rotary actuator to VDI / VDE 3845

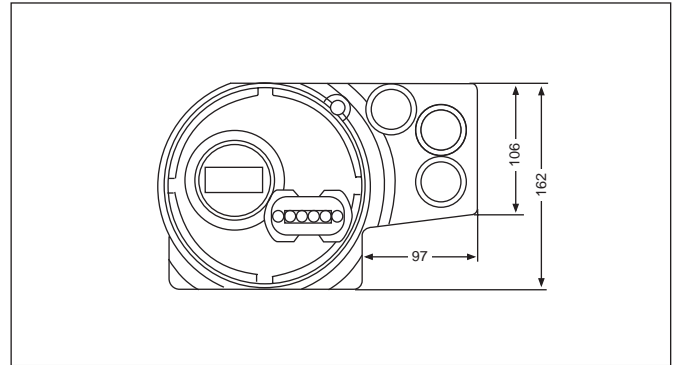

Front view

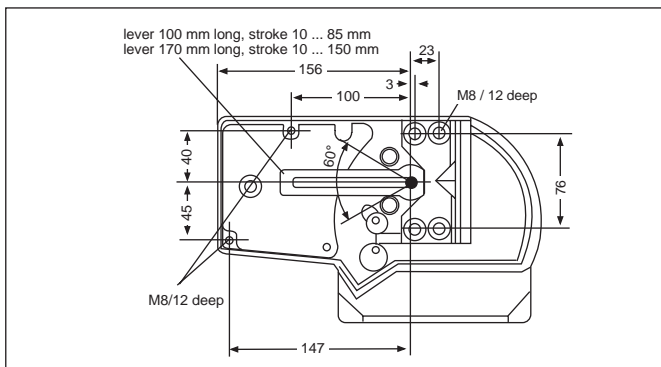

Rear view

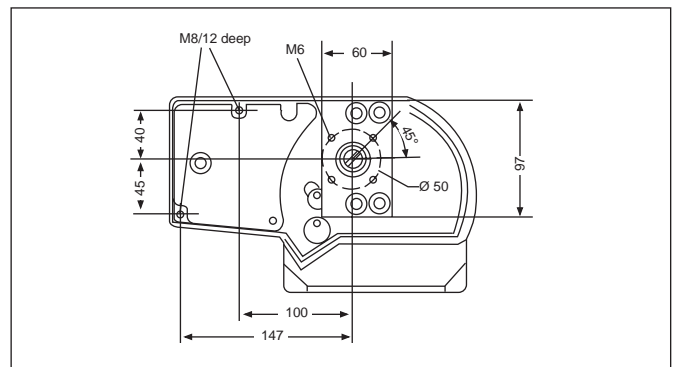

Rear view

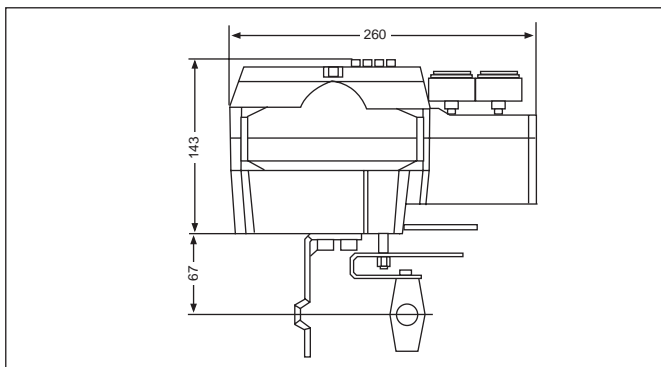

Bottom view

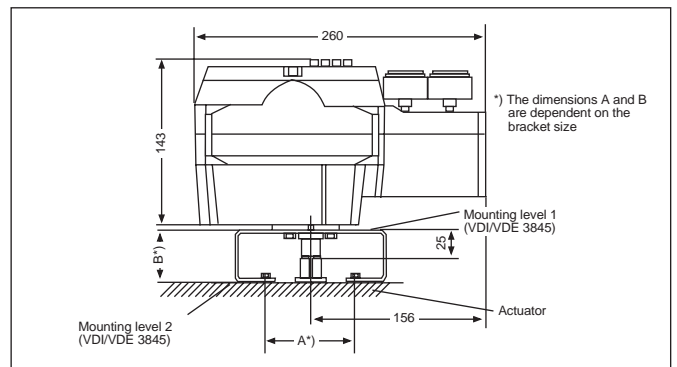

Bottom view

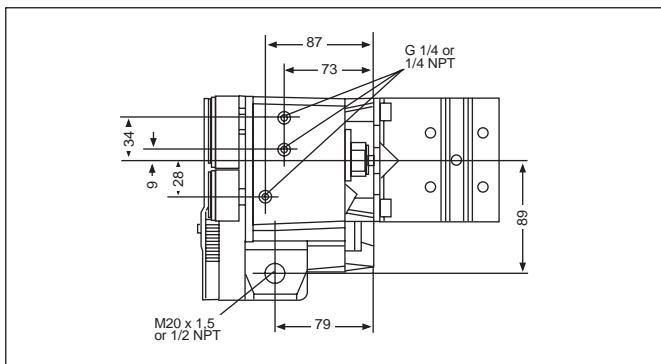

Side view (right)

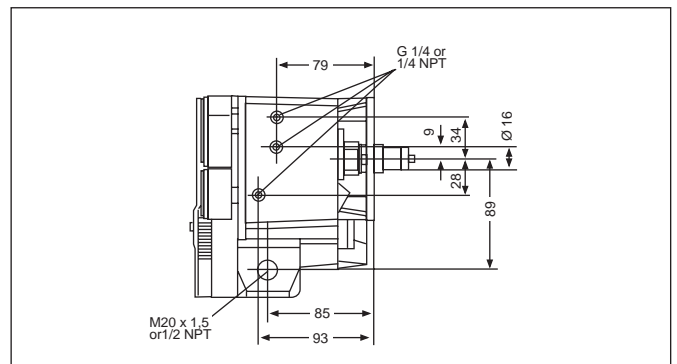

Side view (right)

EP0030EN.EPS

Terminal diagrams

Terminal layout of TZID

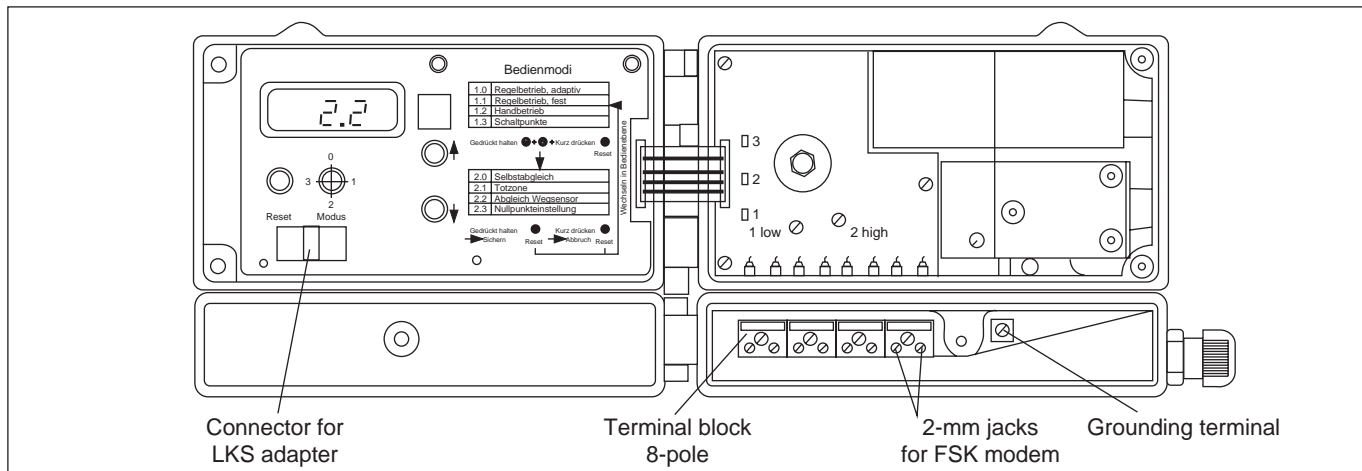

Terminal layout of TZID Ex d

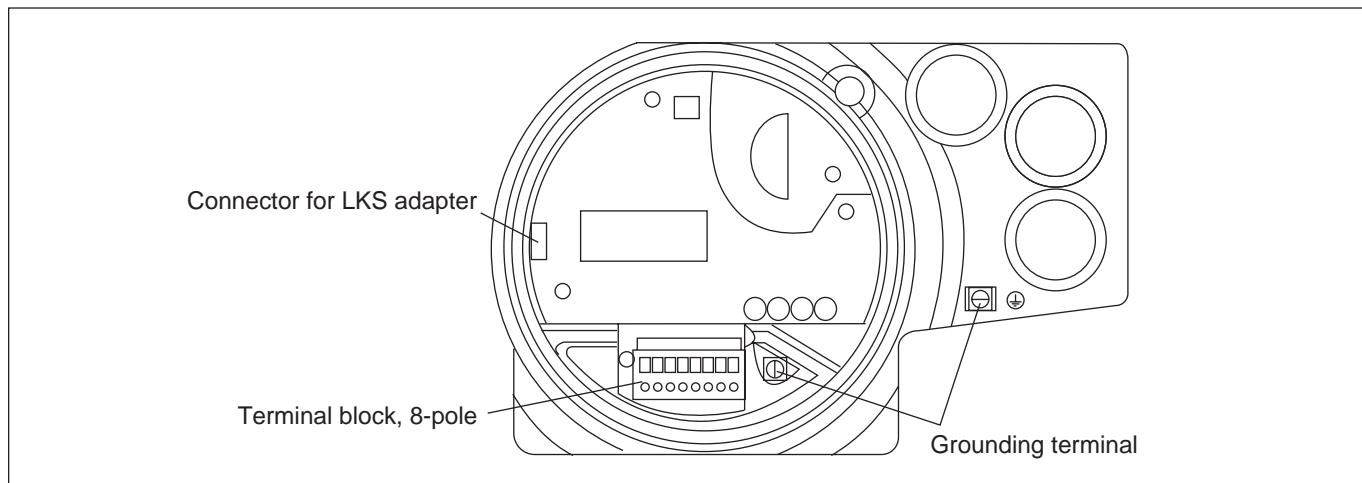

Assignment of 8-pole terminal block

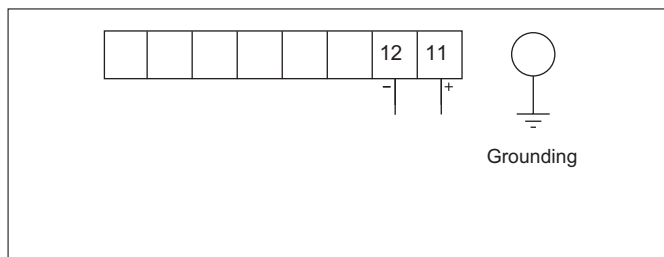

Basic model

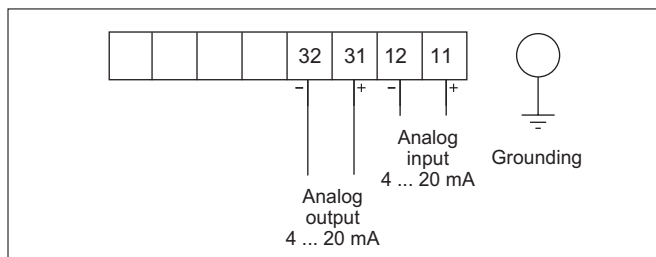

Basic model with "analog position feedback" module

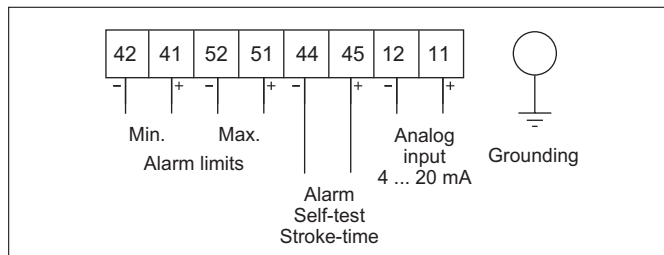

Basic model with "digital position feedback" module

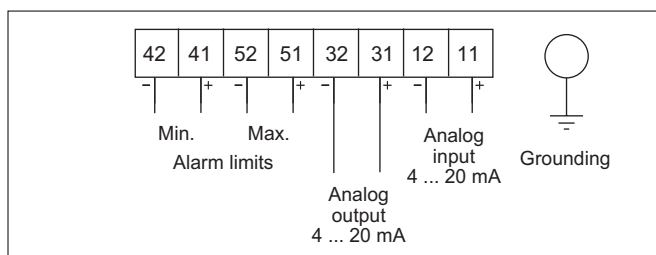

Basic model with "analog position feedback" module and mechanical kit for "digital position feedback"

EP0028EN.EPS



ABB Automation Products GmbH

Schillerstraße 72
D-32425 Minden
Tel. (05 71) 8 30 - 0
Fax (05 71) 8 30 - 18 60
<http://www.abb.de/automation>

Subject to technical changes
Printed in the Fed. Rep. of Germany
10/18-0.20 EN 10.99